

TURBO-SPRITZE EVO 400



TURBOEVO
SPRITZE

TURBO-SPRITZE EVO 400 DIN EN 15182 DATA SHEET



The AWG TURBO-SPRITZE EVO 400 is a hollow jet pipe according to DIN EN 15182 with adjustable jet shape at adjustable constant flow.

The AWG TURBO-SPRITZE EVO 400 is designed to fight various type of fires. These nozzles fulfil numerous national and international standards and can be used for inside as well as outside attack.

A Unit of IDEX Corporation



TURBO-SPRITZE EVO 400

Feature:

- Universally applicable
- Designed for efficient inside attack
- Optimized for cooling of heated inside areas
- Maximum working pressure: 16 bar
- Flow settings: 130 ; 235 ; 400 l/min at 6 bar

Material:

Body: anodized aluminum alloy
Bumper: EPDM
Pistol grip & Lever: PP, PA, ABS

Sketch:

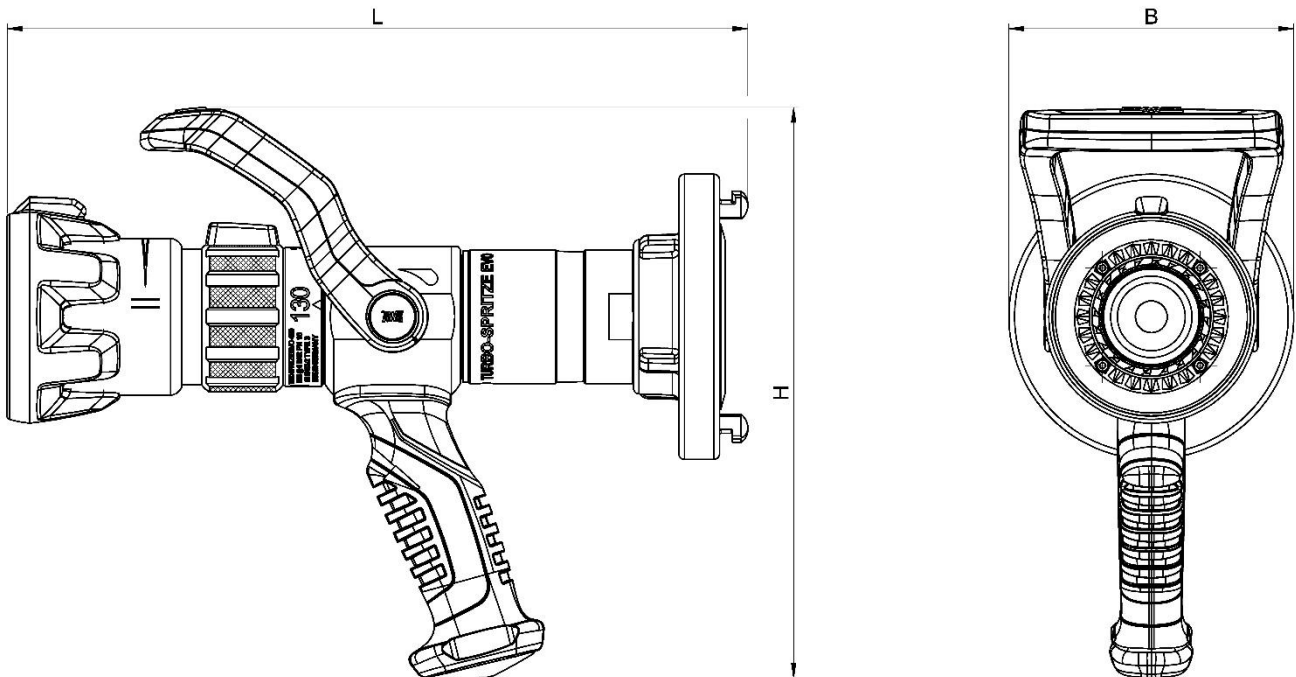

TURBO-SPRITZE EVO 400

Technical specifications:

Id.-Nr.	Inlet	Length	Width	Height	Weight	Nominal pressure	Turbo wheel	Handle	Spray angle
		[mm] L	[mm] B	[mm] H	[kg]	[bar]			
11203333	BSP G 2" male	295	120	250	2,1	16	■	■	0 - 120
11201733	Storz 75 (B)	330	126	250	2,6	16	■	■	0 - 120
11202433	Storz 52 (C)	300	120	250	2,3	16	■	■	0 - 120

TURBO-SPRITZE EVO 400

General data:

Manufacturer	AWG Fittings GmbH
Type	TURBO-SPRITZE EVO 400
Type according to EN 15182-1 Annex A	EN 15182-2 Type 3
Flowrate settings	130 ; 235 ; 400 l/min at 6 bar
Type of spray	full cone spray

Flow – pressure chart:

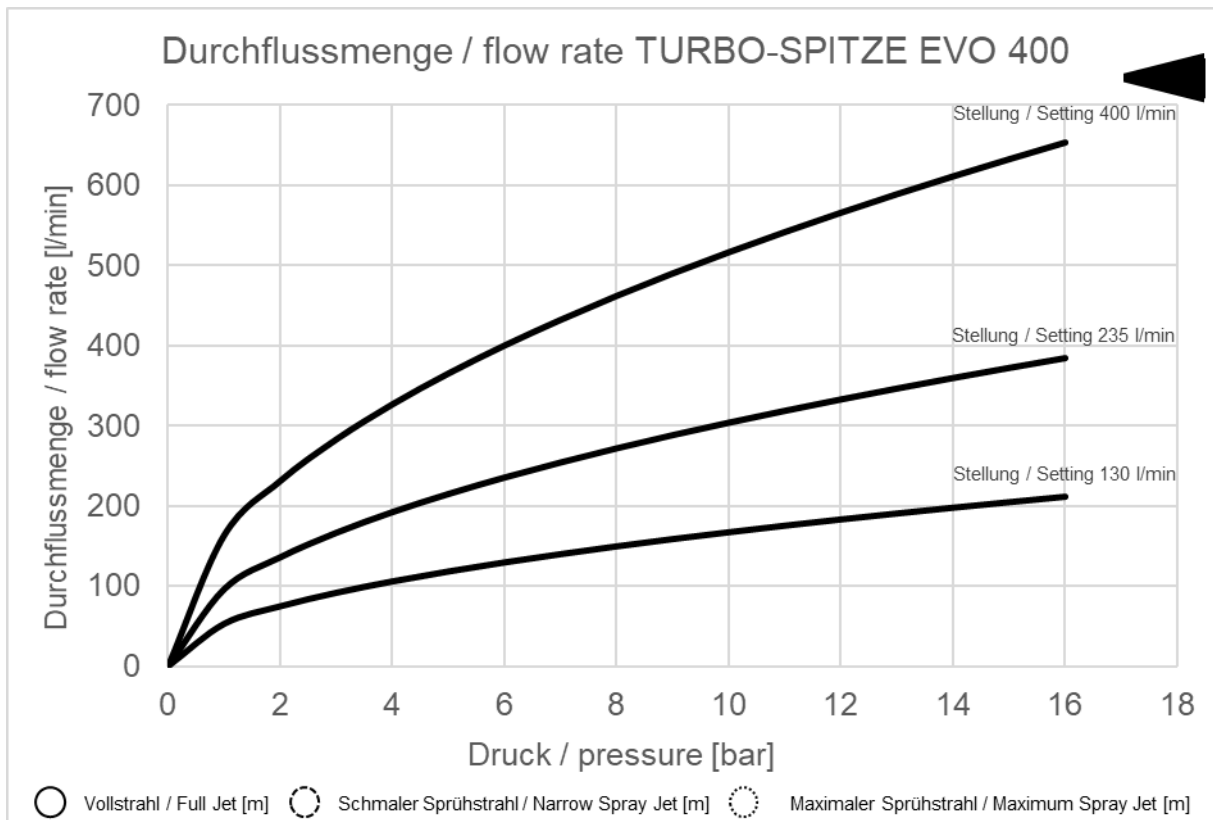

Throw distance at reference pressure p_R of 6 bar:

	Vollstrahl / Full Jet [m]	Schmaler Sprühstrahl / Narrow Spray Jet [m]	Maximaler Sprühstrahl / Maximum Spray Jet [m]
Stellung / Setting 130 l/min	26	15	11
Stellung / Setting 235 l/min	32	18	14
Stellung / Setting 400 l/min	40	23	16

TURBO-SPRITZE EVO 400

Operational devices:

3.1 Fitting system	Swivelling
3.2 Gripping device	Pistol grip
3.3 Open / shut-off device	Ball valve
3.4 Jet / spray system	Rotating operating element
3.5 Flow adjustment system	Rotating operating element

Conditions:

EN 15182-2	Item	Minimum required	Test result
------------	------	------------------	-------------

Operating and Handling	Dimension [mm]	450 x 300 x 150	295 x 250 x 117
	Mass [kg]	3,5	2,1
	Torques, needed for moving operating elements [Nm]		
	Lever	not applicable	not applicable
	Valve Lever	max. 15	<7
	Flow adjustment element	max. 10	1,3
	Jet adjustment element	max. 10	1,3
	Rotating inlet element	max. 5	3
	Flow adjustment Rotation from minimal to maximal flow.	max. 180°	160°
	Jet adjustment Rotation from straight jet to wide spray jet	70° - max. 180°	80°

Performance	Straight jet		
	Effective throw [m]	min. 32	38
	Spray jet		
	Wide spray jet: angle	min. 100°	120°
	Narrow spray jet: angle	min. 30°	60°

Physics	Sensitivity to frost [°C]	min. -32	-35
	Sensitivity to heat [°C]	min. 57	60
	Non-obstruction test [mm]	min. 4,76	6
	Burst pressure [bar]	min. 60	>60